

Linerless Label Applicator with Direct Thermal Printer

# CTW-AM500

for Clear Thermal Wrapping Linerless Label

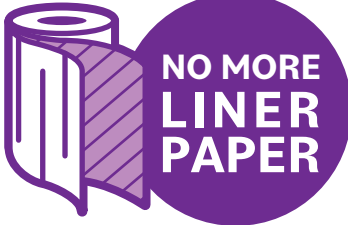

- Print any variable information on the Clear Thermal Wrapping Linerless Label
- Show the contents through high transparency film label
- Support various package shapes and also able to apply non flat bottom



OSP AUSTRALIA PTY LTD

# CTW-AM500

for Clear Thermal Wrapping Linerless Label

## Specifications

Model	CTW-AM500-au
Dimensions	1,820x1,365x1,860 mm 71.65x53.75x73.25 inch
Weight	about 1,000kg (2,200 lb)
Power Supply	AC240V 50Hz
Power Usage	Max. 1kw
Compressed Air	80L/min
Print Resolution	12 dots/mm (approx. 300dpi)
Print Width	165mm (6.5inch) x 2
Print Length	50.08~101.6mm (2~4 inch)
Wrapping Speed	Max.45 packages/min

\*These specifications are subject to change for improvement without prior notice.

## Recommended operating conditions

Temperature	0~35°C(32~95F)
Humidity	30~85%RH

## Supported Label

Label Width	240~500mm (approx. 9.5~19.5 inch)
Label Length	50.08~101.6mm (2~4 inch)
Adhesive Pattern	12mm x 2 Lines
Roll Length	200m
Inner Diameter	76mm (approx. 3 inch)

## Supported Package

Width	75~250mm (approx. 3~10 inch)
Length	110~300mm (approx. 4.25~12 inch)
High	35~100mm (approx. 1.5~4 inch)



## Dimensions (unit:mm)

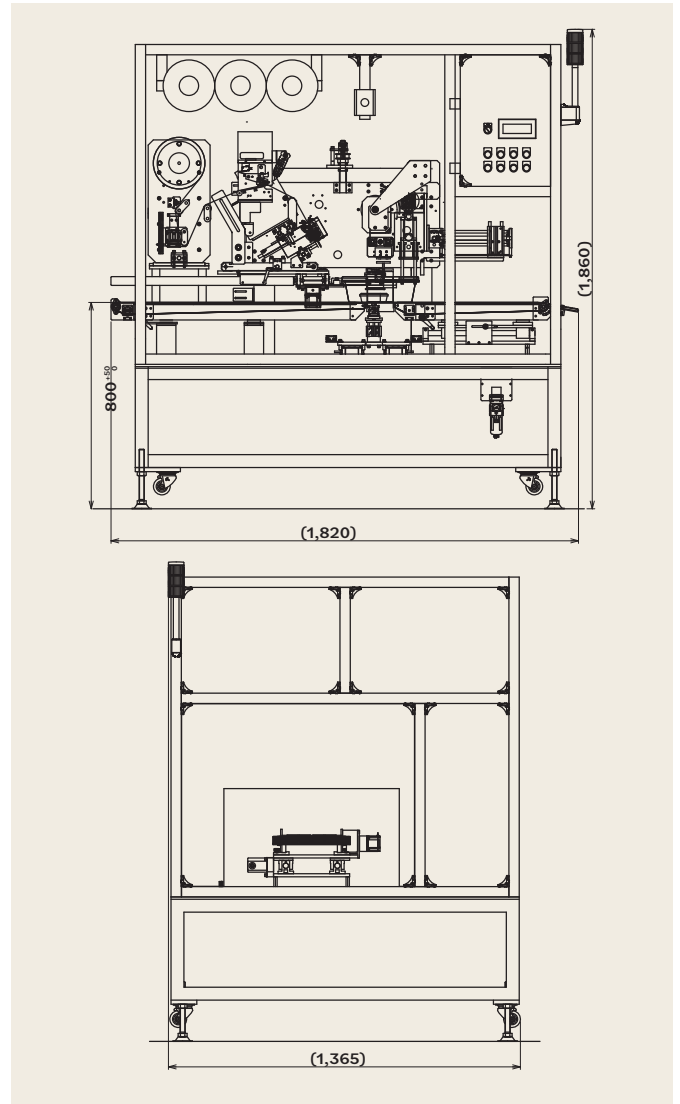

Please visit our show room.

**Clear Wrapping Linerless Label LAB.**



**OSP AUSTRALIA PTY LTD**

Suite 130, 15 Hall Street, Port Melbourne, VIC 3207 Australia



WEB SITE

CTW-AM500-au-tr 2024.03