

Linerless Label Applicator with Direct Thermal Printer

CTW-AH500

for Clear Thermal Wrapping Linerless Label

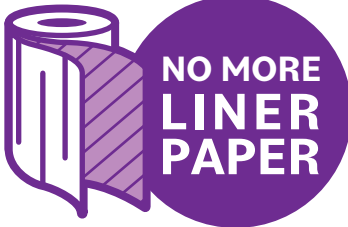

- Print any variable information on the Clear Thermal Wrapping Linerless Label
- Show the contents through high transparency film label
- Support various package shape and also able to apply non flat bottom



OSP AUSTRALIA PTY LTD

CTW-AH500

for Clear Thermal Wrapping Linerless Label

Specifications

Model	CTW-AH500-au
Dimensions	2,150x1,450x1,900(2,450) mm 84.65x57.01x74.80(96.45)inch
Weight	about 1,100kg (2,400 lb)
Power Supply	AC240V 50Hz
Power Usage	Max. 1kw
Compressed Air	80L/min
Print Resolution	12 dots/mm (approx. 300dpi)
Print Width	165mm (6.5inch) x 2
Print Length	50.08~101.6mm (2~4 inch)
Wrapping Speed	Max.60 packages/min

*These specifications are subject to change for improvement without prior notice.

Recommended operating conditions

Temperature	0~35°C(32~95F)
Humidity	30~85%RH

Supported Label

Label Width	320~500mm (approx. 12.75~19.5 inch)
Label Length	60.325~120.65mm (2.375~4.75 inch)
Adhesive Pattern	12mm x 3 Lines
Roll Length	200m
Inner Diameter	76mm (approx. 3 inch)

Supported Package

Width	100~260mm (approx. 4~10 inch)
Length	110~360mm (approx. 4.25~14 inch)
High	50~150mm (approx. 2~5.75 inch)

Dimensions (unit:mm)

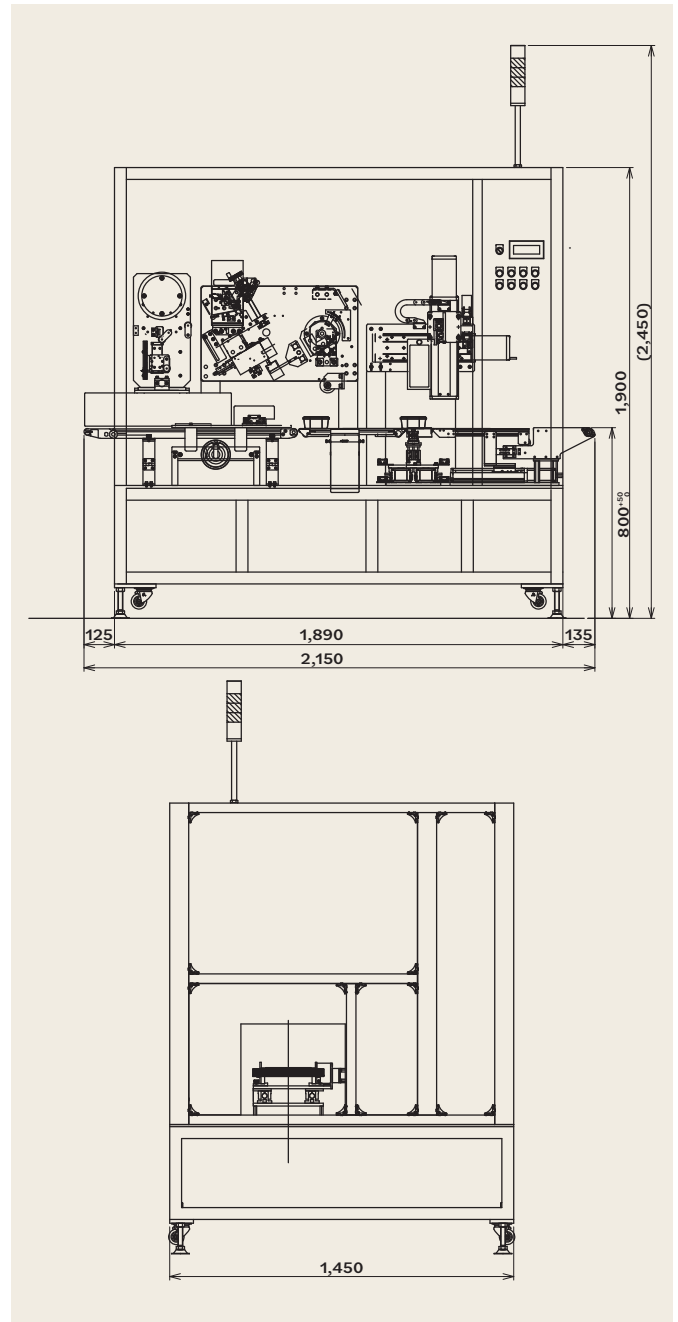

Please visit our show room.

Clear Wrapping Linerless Label LAB.



OSP AUSTRALIA PTY LTD

Suite 130, 15 Hall Street, Port Melbourne, VIC 3207 Australia



WEB SITE

CTW-AH500-au-tr 2024.03